

ATTACHMENTS + EXPANSION GUIDE

For steel sections coated with Fireshield fire rated intumescent coatings.

This Fireshield Guide is designed to help Architects and Contractors when reducing expansion gaps or fixing attachments to fire rated steel members coated with Fireshield® intumescent systems.

INTRODUCTION

Fireshield® has conducted fire test programmes with various systems to provide technical justification for using various attachments and reducing the expansion zone when using Fireshield® intumescent coatings.

The following attachments are approved and contained in this guide:

1. Timber framing and blocking + plasterboard linings.
2. Steel stud light gauge framing.
3. Fireshield + Korok fire walls.
4. Services clips, brackets and attachments.

The Fire Protection Association of New Zealand (FPANZ) publish the intumescent industry guide Code of Practice for Intumescent Coatings. In this document it states where cladding systems or timber framing are to be used in conjunction with an intumescent coating for protecting steel members from fire:

- A gap of 50 times the DFT of the intumescent coating will generally need to be provided (for thin film intumescent coatings) to allow for full expansion of the intumescent coating during a fire.
- Gap sizes may be reduced only where the intumescent coating Manufacturer has specific test evidence to justify a reduction for the specified period of fire resistance.
- This guidance also applies to the gap between the cladding/ framing and the flat surfaces of the protected steel section, as well as to flange tips.
- Where the cladding is mounted onto continuous linear fixings/ spacers, made of timber or metal, the spacers should be considered as a part of the main steel section and duly protected from fire, unless other supporting fire test evidence can be provided to justify alternative action.

This guide provides the Fireshield systems, justification and available test data to comply with the FPANZ COP to reduce gap sizes and use various fixings to coated surfaces.

The details of each system are contained in the following pages, a summary of each is found in Section 2 Attachment and Expansion Summary.

The following documentation is available from Fireshield:

- Full project documentation review of all construction details.
- Project specific Consultant Advice Notice detailing the use of the Fireshield Attachments + Expansion Guide.
- PS1/PS4, PN22 and SFA if required.

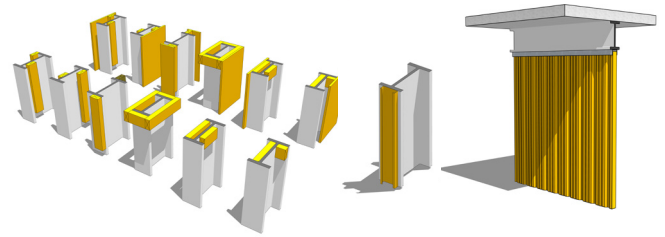

- Full consent package including loading schedule, specification and structural 3D mark up.

ATTACHMENT + EXPANSION SYSTEM SUMMARY

1. Attached timber framing and blocking $\geq 45\text{mm}$ and plasterboard to the coated surface of a steel member.

≤ 60 mins FRR protection use the following Fireshield products:

- Fireshield® Steel 1001
- Fireshield® Steel 1002
- Fireshield® SQ476
- Fireshield® 920KS

60 to 120 mins FRR protection use the following Fireshield products:

- Fireshield® Steel 1002

2. Attached steel stud light gauge framing to the coated surface of a steel member.

≤ 60 mins FRR protection use the following Fireshield products:

- Fireshield® Steel 1001
- Fireshield® Steel 1002
- Fireshield® SQ476
- Fireshield® 920KS

3. Attach Korok wall panels to the coated surface of a steel member to create 2 way fire walls.

≤ 60 mins FRR protection use the following Fireshield products:

- Fireshield® Steel 1001

60 to 120 mins FRR protection use the following Fireshield products:

- Fireshield® Steel 1002

4. Attach service clips, brackets and attachments to the coated surface of a steel member.

- Fireshield® Steel 1001
- Fireshield® Steel 1002
- Fireshield® SQ476
- Fireshield® 920KS

Before specifying these systems contact Fireshield® and we will design a project specific package to ensure your details comply with our testing parameters.

1. TIMBER FRAMING + PLASTERBOARD

Attaching timber framing $\geq 45\text{mm}$ and/or Plasterboard to Fireshield intumescent products

SYSTEM INFORMATION

30 and 60 mins FRR (30/-/- & 60/-/-)

FIRESHIELD PRODUCT	PRODUCT TYPE	TDS REFERENCE	FIRE TEST CODE
Fireshield® Steel 1001	Waterborne single pack - Interior C1-C2	TD-FS1001AUNZ-03	ST-2019-01-01 + ST-2021-01-04/03
Fireshield® Steel 1002	Waterborne single pack- Interior C1-C2	TD-FS1002NZ-01	ST-2021-01-04/01 + ST-2021-01-04/05
Fireshield® SQ476	Solvent single pack -Interior C1-C2	TD-FSSQAUNZ-04	KCC-A22-01
Fireshield® 920KS	Solventless 2- pack epoxy - Interior + Exterior C1-C5	TD-FS920KS-NZ-02	H-22.02.2023 / Issue 1

120 mins FRR (120/-/-)

FIRESHIELD PRODUCT	PRODUCT TYPE	TDS REFERENCE	FIRE TEST CODE
Fireshield® Steel 1002	Waterborne single pack- Interior C1-C2	TD-FS1002NZ-01	ST-2021-01-04/01 + ST-2021-01-04/05

SYSTEM REQUIREMENTS

Steel Sections	Hollow and open columns and beams.
Timber depth	$\geq 45\text{mm}$, see Fireshield for $<45\text{mm}$
Timber width	Any
Fixings	Mechanical
Plasterboard Type	Any up to 13mm.

INSTALLATION

1. Coat the structural steel member with the Fireshield intumescent system at the required dry film thickness (DFT) from the Fireshield loading schedule. Complete DFT survey and QA before fixing to the coated surface.
2. Attach and mechanically fix the timber stud to the coated steel member.
3. Attach plasterboard as required using manufacturers instructions, do not use adhesive on the coated steel surface. Plasterboard can be hard against the coated surface.

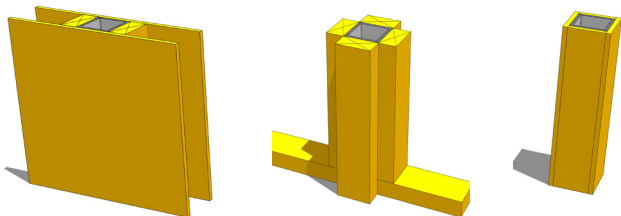

Fig. 1 Closed columns/beams examples

COMPLIANCE INFORMATION

- Fireshield performed fire testing as per the FPANZ COP-03 v2. Temperature/time curve readings were taken at the timber to steel interface and compared to reference test data.
- The tests provide recommendations on reducing the expansion zones required when using Fireshield intumescent coatings and to show the effects of timber strapping and plasterboard attached directly to the coated steel member.
- The fire test results concluded that the intumescent coating operated as expected and continued to provide compliance with the NZBC B1/VM1 and C2/AS1-C6/AS1 Section C5.1.1 and the NCC Volume 2, Schedule 5

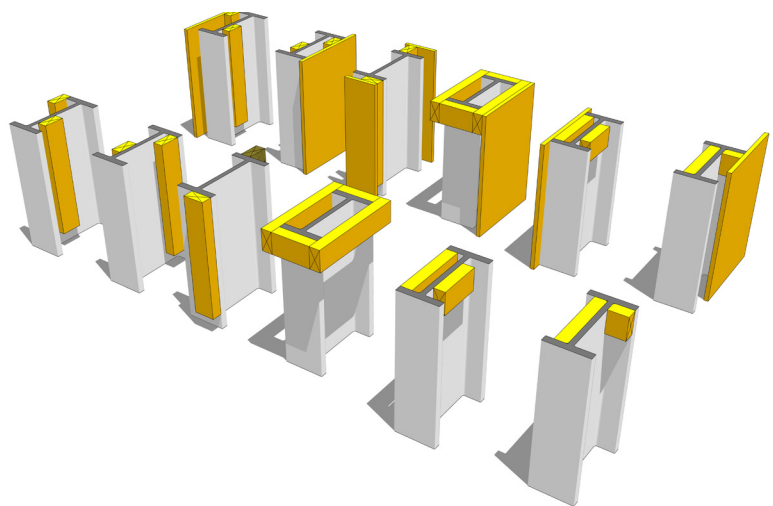

Fig. 2 Open columns/beams examples

RECOMMENDATIONS

This fire test evidence can be used to engineer a solution that allows a structural steel section to be coated with the listed Fireshield intumescent and timber stud with or without plasterboard linings attached. This is a summarised version of the fire test report, for a copy of the original detailed report, email technical@fireshieldcoatings.com.

2. STEEL STUD LIGHT GAUGE FRAMING

Attaching light gauge steel channel framing to Fireshield intumescent products

SYSTEM INFORMATION

30 and 60 mins FRR (30/-/- & 60/-/-)

FIRESHIELD PRODUCT	PRODUCT TYPE	TDS REFERENCE	FIRE TEST CODE
Fireshield® Steel 1001	Waterborne single pack - Interior C1-C2	TD-FS1001AUNZ-03	TK-220701-01
Fireshield® Steel 1002	Waterborne single pack- Interior C1-C2	TD-FS1002NZ-01	TK-220701-01
Fireshield® SQ476	Solvent single pack -Interior C1-C2	TD-FSSQAUNZ-04	TK-220701-01
Fireshield® 920KS	Solventless 2- pack epoxy - Interior + Exterior C1-C5	TD-FS920KS-NZ-02	TK-220701-01

SYSTEM REQUIREMENTS

Steel Sections	Hollow and open columns and beams.
Steel stud	≥ 0.95 galvanised steel stud
Fixings	Mechanical
Steel stud channel	Coat with intumescent.

INSTALLATION

1. Coat the structural steel member with the Fireshield system at the required dry film thickness (DFT) from the Fireshield loading schedule. Complete DFT survey and QA before fixing to the coated surface.
2. Attach and mechanically fix the steel stud channel as per Manufacturers instructions.
3. Coat the attached steel channel with the same dry film thickness as the main structural member it is attached to.

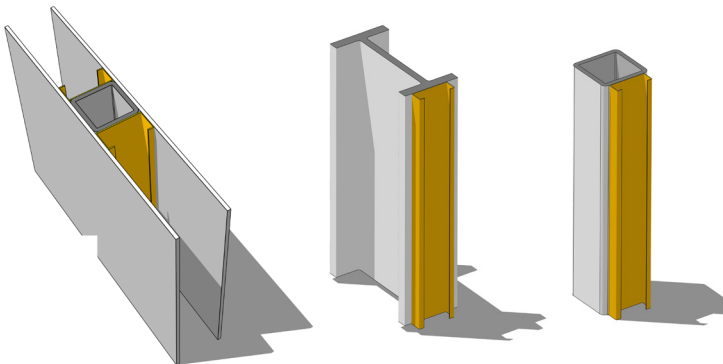

Fig. 3 Closed columns/beams examples with coating applied to steel stud channel.

COMPLIANCE INFORMATION

- Fireshield undertook fire tests as per the FPNZ COP-03 v2. Temperature/time curve readings were taken at the steel interface and compared to reference test data.
- The test was to provide recommendations on the expansion zones required when using Fireshield intumescent coatings and to show the effects of steel studs attached directly to the coated steel member.
- The fire test results concluded that the intumescent coating operated as expected and continued to provide compliance with the NZBC B1/VM1 and C2/AS1-C6/AS1 Section C5.1.1 and the NCC Volume 2, Schedule 5

ALTERNATIVE SOLUTIONS:

Below is the solution to attach a steel stud channel to a coated structural steel member without having to coat the steel stud with the Fireshield intumescent.

1. Z Clips or steel spacers can be used to provide the expansion gap between the coated steel section and the steel frame. The Z clips or spacers must comply with Section 4 of this document for size and frequency.
1. Attach 90X45 timber plate to the coated steel column/beam to comply with the systems on page 2 of this document.
2. Attach steel stud to the 90X45 timber plate.
3. Finally attach the steel stud channel to the timber plate.

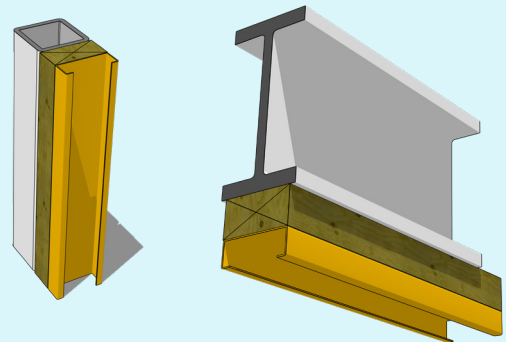

Fig. 4 Closed columns/beams examples using alternative fixing option.

RECOMMENDATIONS

This fire test evidence can be used to engineer a solution that allows a structural steel section to be coated with the listed Fireshield intumescent and steel stud channel with or without plasterboard linings attached. This is a summarised version of the fire test report, for a copy of the original detailed report, email technical@fireshieldcoatings.com.

3. FIRESHIELD + KOROK FIRE WALLS

Attaching Korok 78mm wall panels to Fireshield coated structural steel to form 2-way fire walls.

SYSTEM INFORMATION

60 mins 2-way fire walls ≤ 60/60/60

FIRESHIELD PRODUCT	PRODUCT TYPE	TDS REFERENCE	FIRE TEST CODE
Fireshield® Steel 1001	Waterborne single pack - Interior C1-C2	TD-FS1001AUNZ-03	FR16707

120 mins 2-way fire walls 120/120/120

FIRESHIELD PRODUCT	PRODUCT TYPE	TDS REFERENCE	FIRE TEST CODE
Fireshield® Steel 1002	Waterborne single pack- Interior C1-C2	TD-FS1002NZ-01	FR16707

SYSTEM REQUIREMENTS

Steel Sections	Hollow and open columns and beams.
Korok Wall Panel	78mm
Fixings	Mechanical
Deflection Head	Korok C Track 60X80X60X1.15 BMT galv.
Mastic Sealant	Hilti CP606 fire rated sealant
PS1/PS4	Required for 2-way fire wall design

COMPLIANCE INFORMATION

- Fireshield undertook fire tests in conjunction with Korok at BRANZ to evaluate the effects of the Korok wall system attached directly to a Fireshield coated beam and column sections up to 120 mins FRR.
- The fire test was to evaluate if the entire wall system could be used as a 2-way fire wall providing structural, insulation and integrity values.
- The Korok wall system should be installed as per the Korok fire systems installation manual.
- The fire test results concluded that the Korok + Fireshield tested system can provide a 2 way fire wall up to 120mins FRR in sprinklered buildings and in non sprinklered with a 50mm standoff distance (less than 25W/m²). The system complies with the NZBC B1/VM1 and C2/AS1-C6/AS1 Section C5.1.1 and the NCC Volume 2, Schedule 5.

INSTALLATION

1. Coat the structural steel member with the Fireshield system at the required dry film thickness (DFT) from the Fireshield loading schedule. Complete DFT survey and QA before fixing to the coated surface.
2. Attach the Korok wall panel as per the Korok fire installation manual and Fireshield TAN, contact Fireshield prior to specifying.

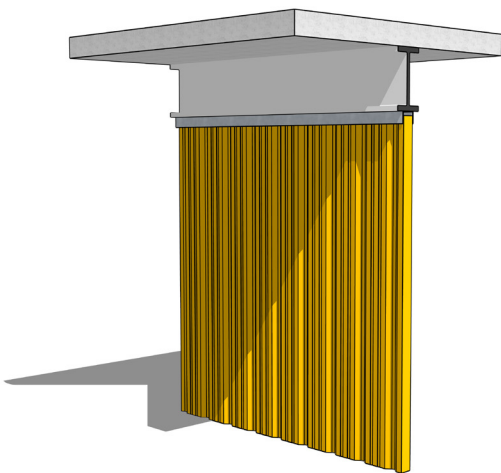

Fig. 5 Closed/open steel beam sections to Korok wall with deflection head.

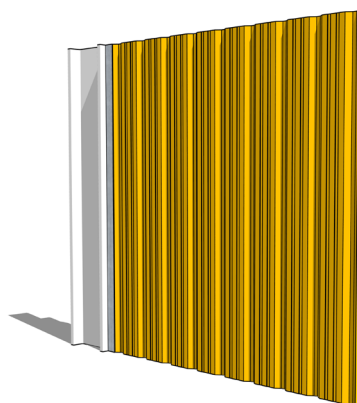

Fig. 6 Open steel column section to Korok wall with deflection head.

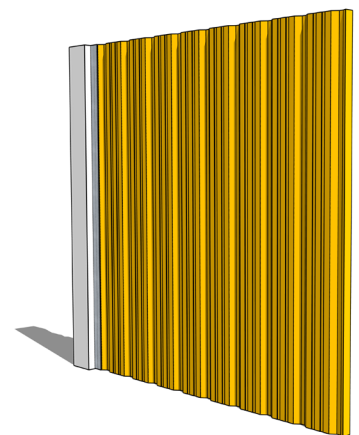

Fig. 7 Closed steel column section to Korok wall with deflection head.

RECOMMENDATIONS

This fire test evidence can be used to engineer a solution that allows a structural steel section to be coated with the listed Fireshield intumescent and connected to the Korok wall system. This is a summarised version of the fire test report, for a copy of the original detailed report, email technical@fireshieldcoatings.com.

4. SERVICE CLIPS + ATTACHMENTS

Attaching Services clips, brackets and attachments to Fireshield intumescent products

SYSTEM INFORMATION

Up to 120 mins FRR (120/-/-)

FIRESHIELD PRODUCT	PRODUCT TYPE	TDS REFERENCE	FIRE TEST CODE
Fireshield® Steel 1001	Waterborne single pack - Interior C1-C2	TD-FS1001AUNZ-03	FABIG Technical Note 13 Section 6.5
Fireshield® Steel 1002	Waterborne single pack- Interior C1-C2	TD-FS1002NZ-01	FABIG Technical Note 13 Section 6.5
Fireshield® SQ476	Solvent single pack -Interior C1-C2	TD-FSSQAUNZ-04	FABIG Technical Note 13 Section 6.5
Fireshield® 920KS	Solventless 2- pack epoxy - Interior + Exterior C1-C5	TD-FS920KS-NZ-02	FABIG Technical Note 13 Section 6.5

SYSTEM REQUIREMENTS

Steel Sections	Hollow and open columns and beams.
Attachments	Service clips and brackets
Attachment Type	Steel, Aluminium, Light Gauge Steel.
Fixing	1 per lineal metre or per m ²
Attachment Size	Up to 3000mm ²

INSTALLATION

1. Coat the structural steel member with the Fireshield system at the required dry film thickness (DFT) from the Fireshield loading schedule. Complete DFT survey and QA before fixing to the coated surface.
2. Attach the required service clips, attachments and brackets to the coated surface, they must be under 3000mm² in size.
3. There can be no more than one fixing per lineal metre or metre square.
4. If fixings are larger than 3000mm² in size or if there are more than one per lineal metre or metre square, coat all fixings with intumescent at the same DFT as the primary fire rated member.

COMPLIANCE INFORMATION

- The Fire and Blast Information Group (FABIG) Technical Note 13 Section 6.5 states that for small attachments such as brackets for cable trays, instrument piping and handrails, the cross sectional area will be small and the resultant heat transfer is not significant.
- Therefore, assuming these do not cumulatively exceed 3000 mm² cross sectional area per metre length of primary steel section or per square metre of surface area, then they generally do not need to be coated.
- The intumescent coating will continue to perform as per the compliance testing and continue to provide compliance with the NZBC B1/VM1 and C2/AS1-C6/AS1 Section C5.1.1 and the NCC Volume 2, Schedule 5.
- For fixings larger than 3000mm² per lineal metre or square metre: coat with the intumescent coating at the same DFT as the protected member they are connected to, this can be considered a coatback to prevent excessive heat transfer.



Fig. 1 Attachment example.



Fig. 2 attachment example.

RECOMMENDATIONS

This fire test evidence can be used to engineer a solution that allows a structural steel section to be coated with the listed Fireshield intumescent and have clips and brackets attached. This is a summarised version, for a copy of the original detailed report, email technical@fireshieldcoatings.com.